



**WE ARE HEUFT!**

*... and HEUFT knows how!*

All-around solutions for the canning line

# HEUFT CAN INSPECTION

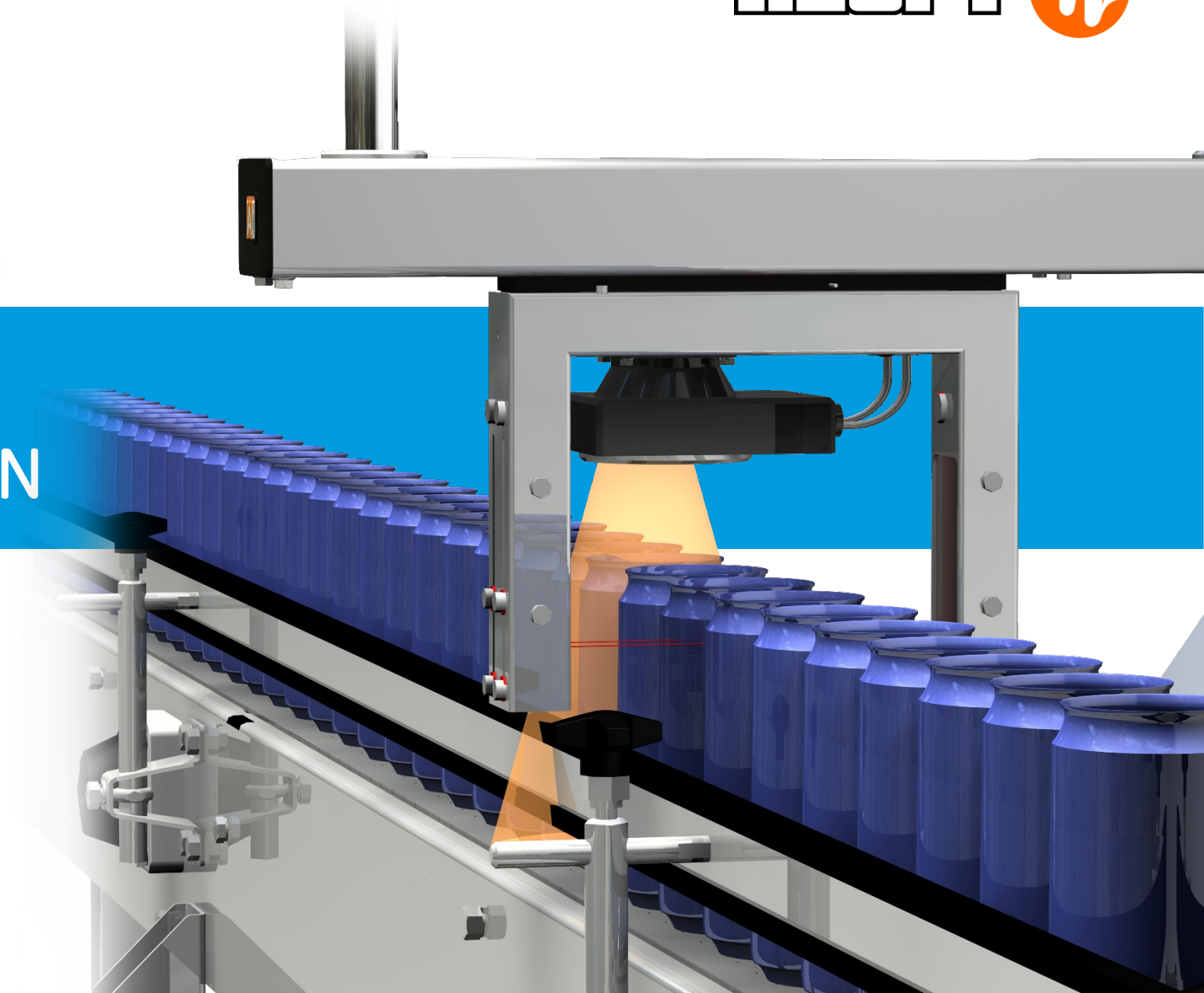

# Safety all around?

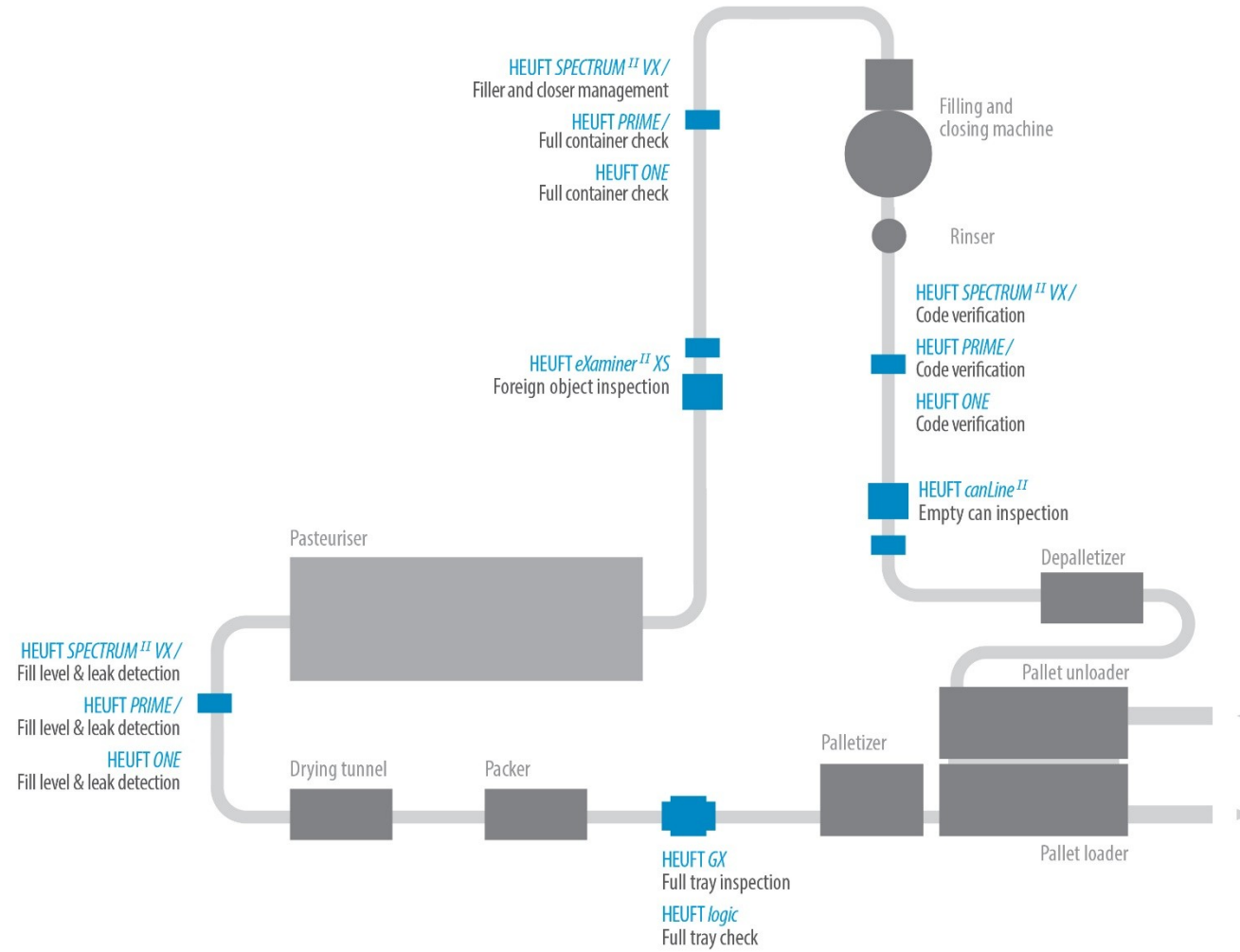





## Filled can inspection with pulsed X-rays

- Inspection for foreign bodies after the filling process
- Inspection of the primary packaging
- The risk of foreign bodies is significantly reduced and product safety increased
- Consumer and brand protection

HEUFT *eXaminer II XS* – foreign body detection

HEUFT *eXaminer II XS*



HEUFT *eXaminer II XS*

- Detection of high density foreign objects like glass or metal
- Easy addition of different inspection units
- Compact design simplifies integration
- High detection accuracy and low false rejection rate



HEUFT *eXaminer II XS* – foreign body detection

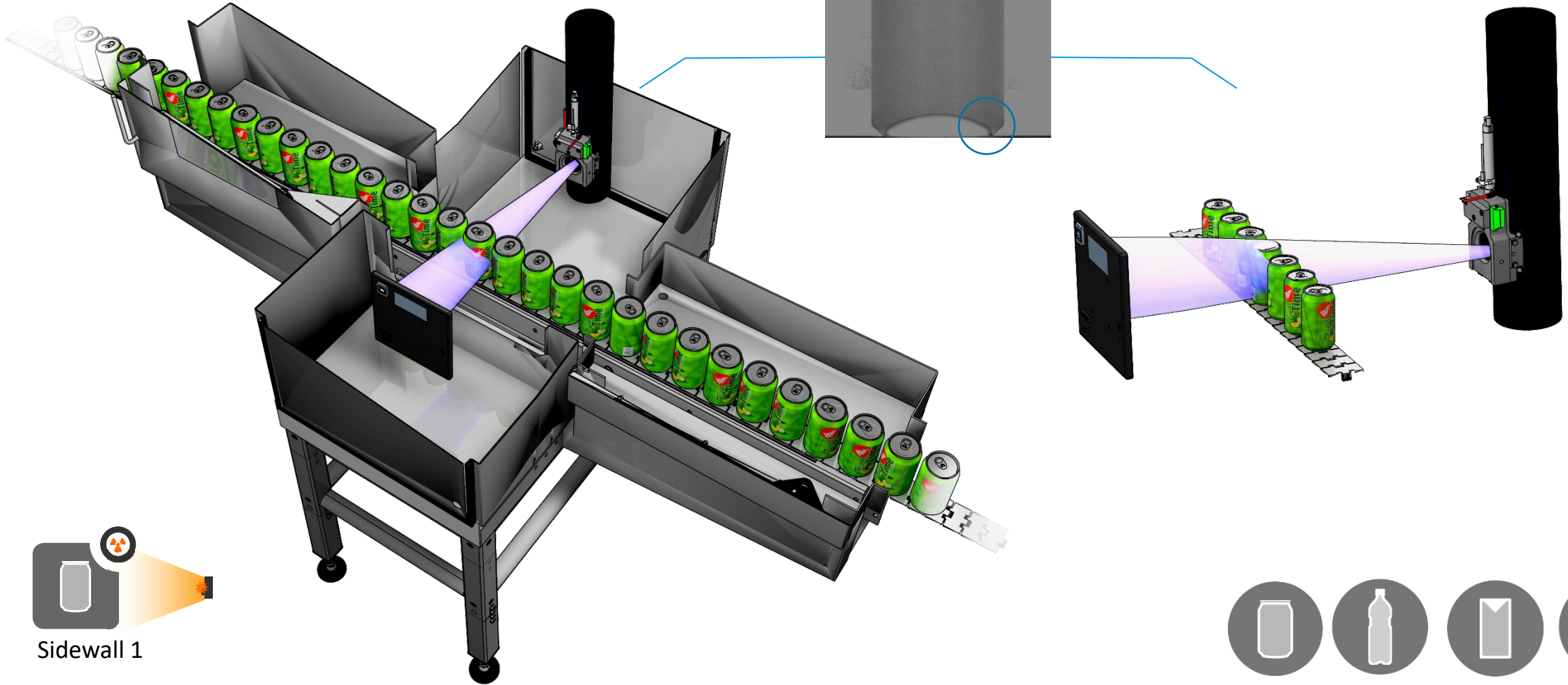

# HEUFT *eXaminer II XS* - single sidewall inspection



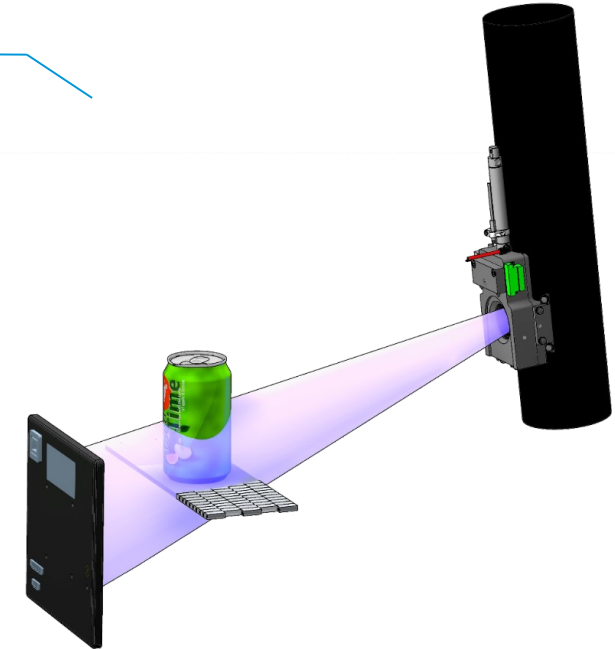
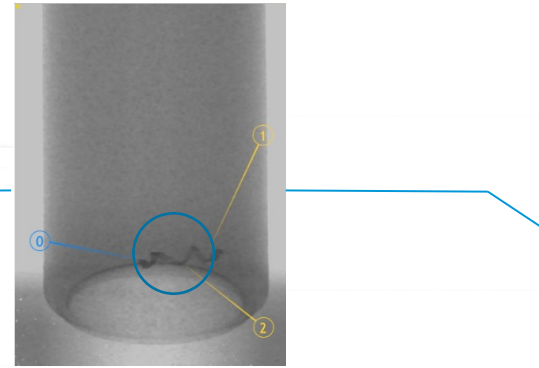
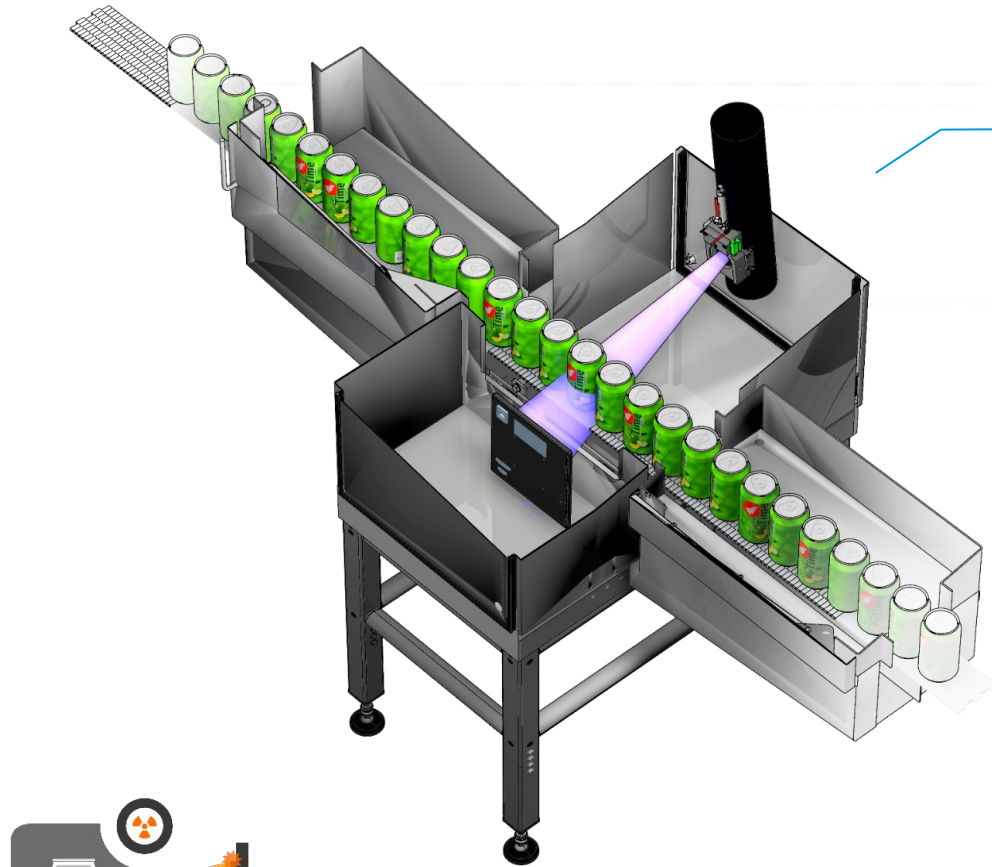

Base inspection



Special chain



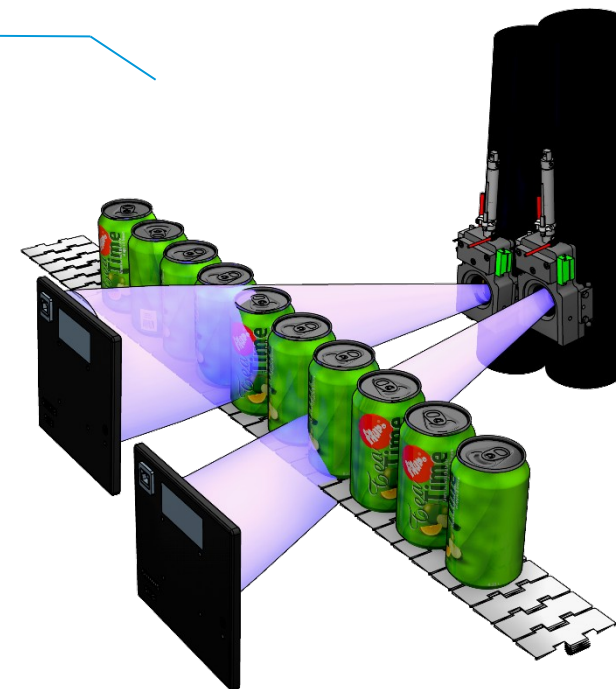
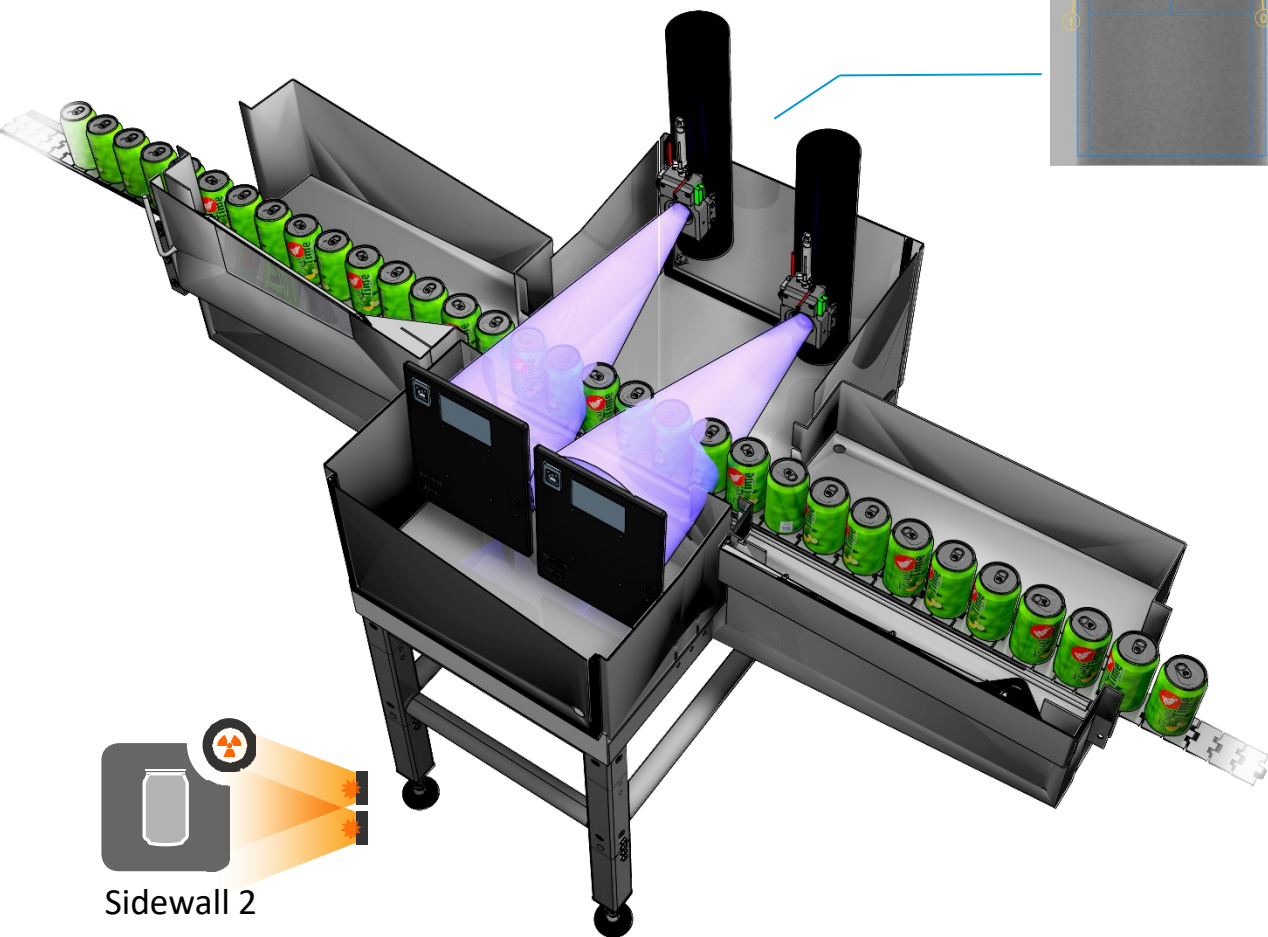
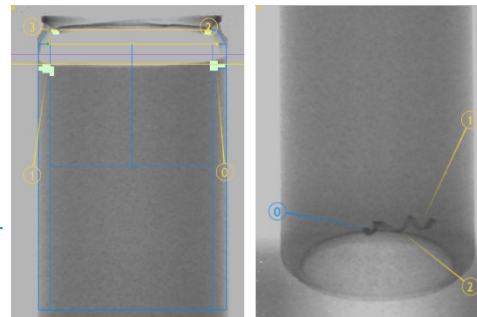

# HEUFT *eXaminer II XS* - double sidewall inspection



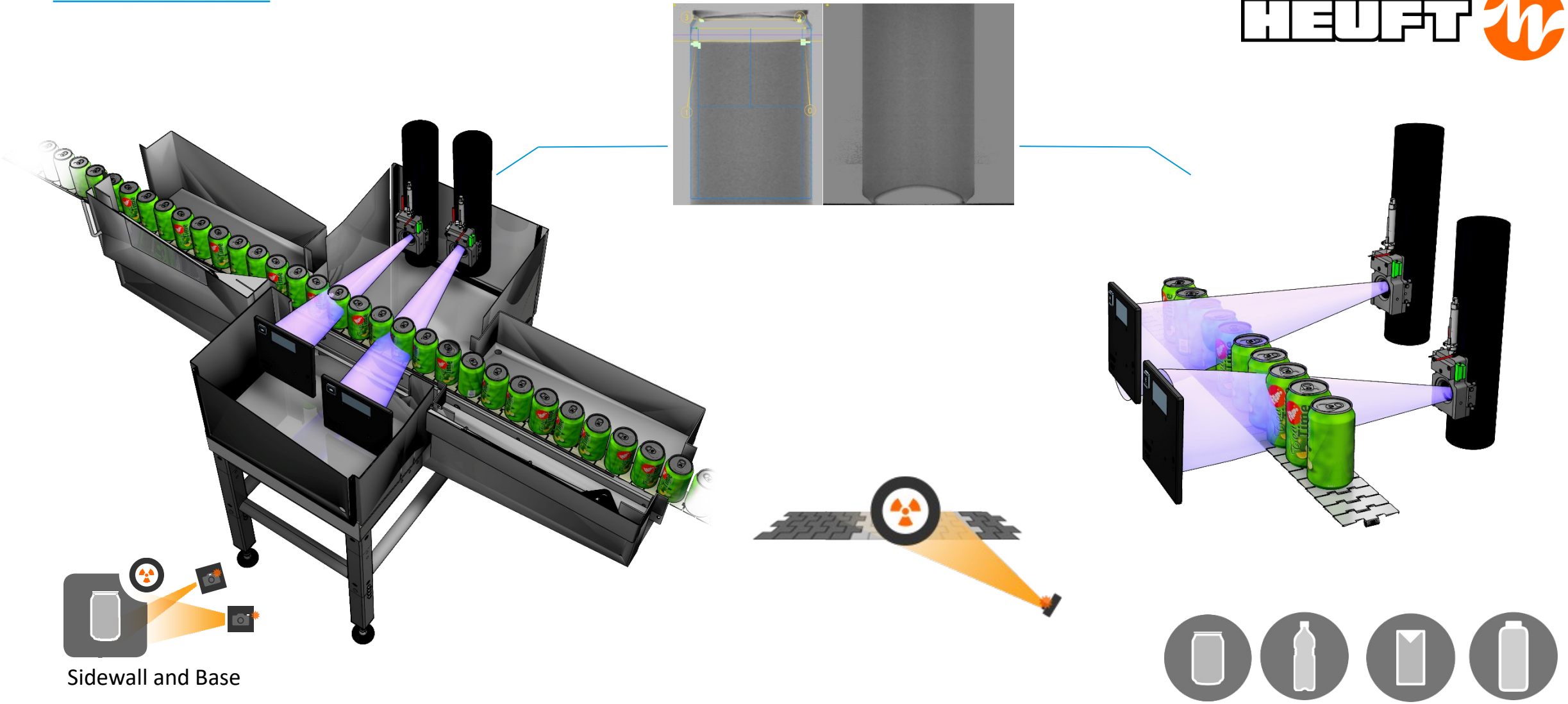

Sidewall and Base

# HEUFT *eXaminer II XS* – sidewall and base inspection

Operating unit

Inspection



MHI

+ Additional inspection modules



Excessive height lid check

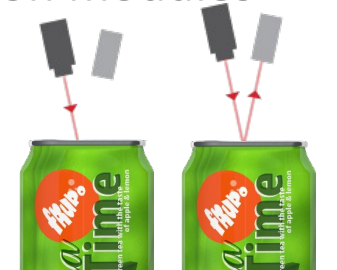

Optical closure presence



Automatic brand change

HEUFT *eXaminer II XS* - space-saving turnkey solution

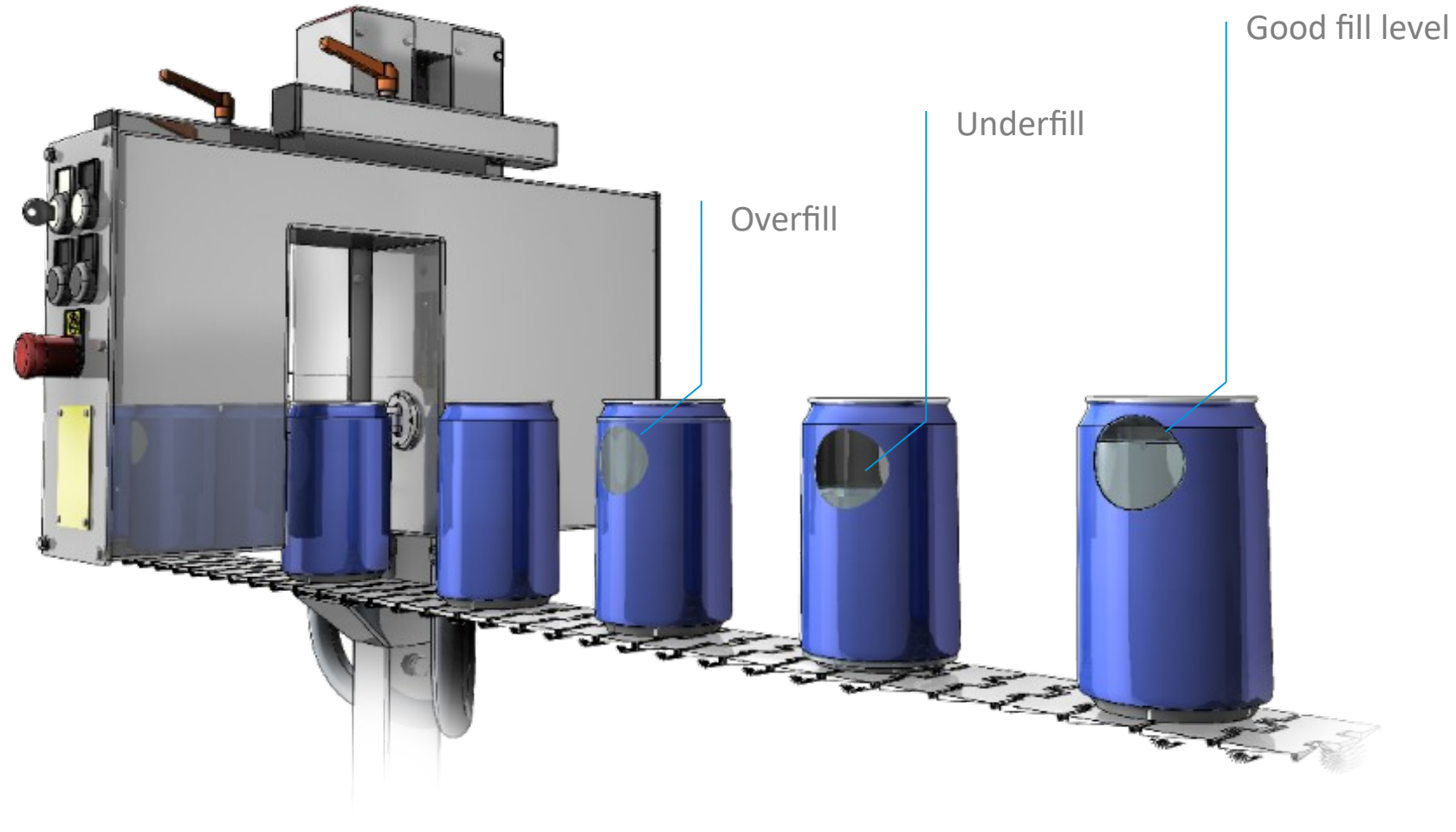

Additional- HEUFT X-ray fill level inspection





Inductive pressure check - ensuring the perfect can closure.